

Agilent

Innovative Applications for an RF/microwave USB Power Meter or Sensor and Power Analysis Manager Software

Application Note



Agilent Technologies

Introduction

Every once in a while, a new product concept comes along which offers engineers a novel way to use their measurement creativity in order to devise their own application setups. In the case of RF and microwave power measurements, Agilent's traditional sensor and meter combination has served since World War II in the 1940s. With the new USB-based power sensor, measurement engineer can now remove the power meter instrument from the conventional measurement process.

We all live in an analog world, but every engineer knows that it is always advantageous to get analog measurement data to be converted into digital format just as close to the measurement point as possible. One of the most ubiquitous examples of this in everyday life is the powerful analog-to-digital converter, typified by the digitized voice converters in every cell phone.

With an RF/microwave power sensor, which converts its input into digital formats, with full characterization of true RMS power, a number of new applications and measurements would be immediately opened up to the measurement engineers.

Introducing the Agilent Model U2000 Series USB Power Sensor

The U2000 Series USB Power Sensor is able to display power measurements on a PC or on other instruments without requiring a separate power meter. The U2000 Series provides the same functionality and performance as a traditional power meter and sensor. It is a complete solution that simplifies your measurement setup and at the same time meets all the measurement needs.

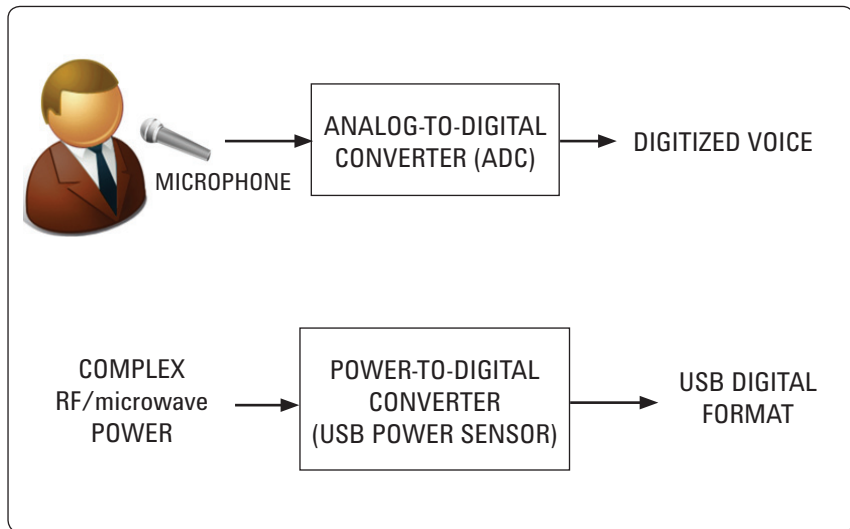

Figure 1 Digitizing analog signals right at the point of sensing provides great measurement and applications flexibility.



Figure 2 The U2000 Series USB Power Sensor allows for immediate conversion of RF/microwave power into digital data right at the point of power sensing.

A New USB Power Sensor Series and Power Analysis Manager Software

The Universal Serial Bus (USB) is no longer a stranger to many and is increasingly gaining favor as an alternative interface in the world of testing and measurements. USB provides easy and wideband data connections to peripheral devices. The U2000 Series USB power sensor is developed based on the technology of our classic microwave diode power sensors, which depended on the stable detection properties of the Low Barrier Schottky (LBS) microwave diode technology. It is able to sense CW and average power within the frequency range of 9 kHz to 24 GHz, and power levels from -60 dBm to +20 dBm at a measurement speed of up to 1000 readings per second in buffered mode. Furthermore, each sensor is able to operate on the DC

power supply of the USB data system and each sensor draws approximately 170 mA from the USB port. Hence, external power cables are not required.

By liberating the power sensing measurement from its traditional electronic power meter instrument, and providing the display and analysis capability on a regular personal computer (PC), a wide variety of new applications can be envisioned. Remote power sensing first comes to mind, measuring power up on a transmitter tower, for example, because sensor cabling is immediately simplified.

Production applications requiring multiple power sensors are also easily

accomplished since multiple U2000 Series sensors' data can be multiplexed to the same computer display. This data can be manipulated for cross-sensor parameters, such as reflection coefficient, component gain measurements, and so forth.

The U2000 Series comes with a powerful companion data analysis and control, the Agilent N1918A Power Panel. It provides a front panel display, a standard graphical user interface (GUI) for the sensor. Thus, making the PC act like a traditional power meter display with both analog and digital displays available simultaneously. Figures 3 to 5 show some typical display options providing powerful applications measurements in various data formats.

The power and frequency coverage of the new family of U2000 Series are:

Agilent Model	Frequency Range	Power Range
U2000A	10 MHz to 18 GHz	-60 dBm to +20 dBm
U2001A	10 MHz to 6 GHz	-60 dBm to +20 dBm
U2002A	50 MHz to 24 GHz	-60 dBm to +20 dBm
U2004A	9 kHz to 6 GHz	-60 dBm to +20 dBm

Higher power level models with capabilities of up to +44 dBm (25 Watts) will be offered soon.



Figure 3 The N1918A Power Panel tool mimics an analog meter of a normal power meter instrument (only larger), and performs a wide variety of data computations.

Most importantly, the N1918A Power Panel software leverages power measurement data available from the data outputs of other power meter instruments like the Agilent P-Series N1911/12A and Agilent N8262A meters. Since those meters and associated peak and average sensors characterize complex power signals, including pulsed, spread spectrum and wireless communications formats, the optional N1918A-100 Power Analysis Manager delivers statistical measurement results with such data like PDF, CDF, and CCDF.

This application note provides adequate internal details of the U2000 Series hardware and the N1918A Power Analysis Manager software to provide the reader engineer with a basic understanding of their operation and performance capabilities. It outlines a number of suggested measurement applications to show typical configurations. It also reviews the basic power measurement theory about calibration, power traceability and measurement uncertainties, using prior references available in other literatures. Finally, it considers sensor detection stability with time and environment, in order to ensure long-term measurement confidence (1 year), even with the sensor being installed remotely.



Figure 4 Strip chart continuous analog monitor of a power channel.

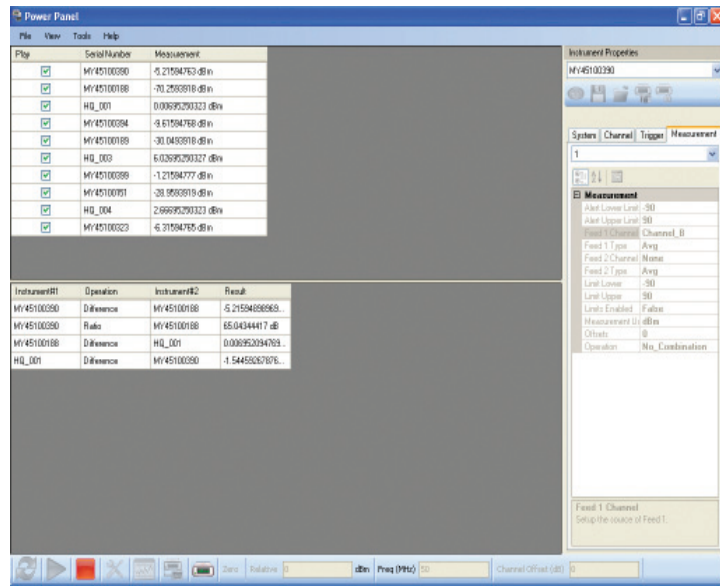

Figure 5 Multiple U2000 Series sensors in multi-list view.

U2000 Series Product Concepts and Capabilities

The U2000 Series is based on the powerful RF/microwave diode sensing technologies which have been exploited by Agilent for over 30 years. Introduced as the HP 8484A sensor in 1975, it utilized the then-new LBS diode technology, which featured metal to semiconductor junctions. Such diode junctions are rugged, highly consistent and repeatable from diode to diode, and reliable in long term measurement. [Ref: 1.2, page 19] Over the years, the diode power sensors have been improved to include balanced (back-to-back) diode configurations and also the addition of two channel adaptations that extended the power dynamic (square-law) range significantly.

Balanced diodes reduce the effect of signal harmonics on the measurement. In addition, later improvements included super-integration of diodes onto a single micro-substrate. A functional block which provides for on-board zeroing is also included on the same substrate, thus removing the need for any operators to unscrew the RF sensor connector from test power signal or to turn off the the test power. In the U2000 Series, 5-diode stacks are used for the high power range which extends the dynamic range square-law detection, and 2-diode stacks for the low power range.

These stack technologies have already been used in previous sensor product lines. By basing the U2000 Series diodes on the popular E9300 Series sensor technology and the on-board zeroing of the P-series (N1921/22A) sensor technology, the new sensors include all the signal conditioning and analog-to-digital formatting functions that have been in use for several years. Thus, users can be assured that the new USB power sensor will deliver highly predictable results. [Ref: 2, pages 24–30] [Ref: 5]

Figure 6 shows an abbreviated block diagram.

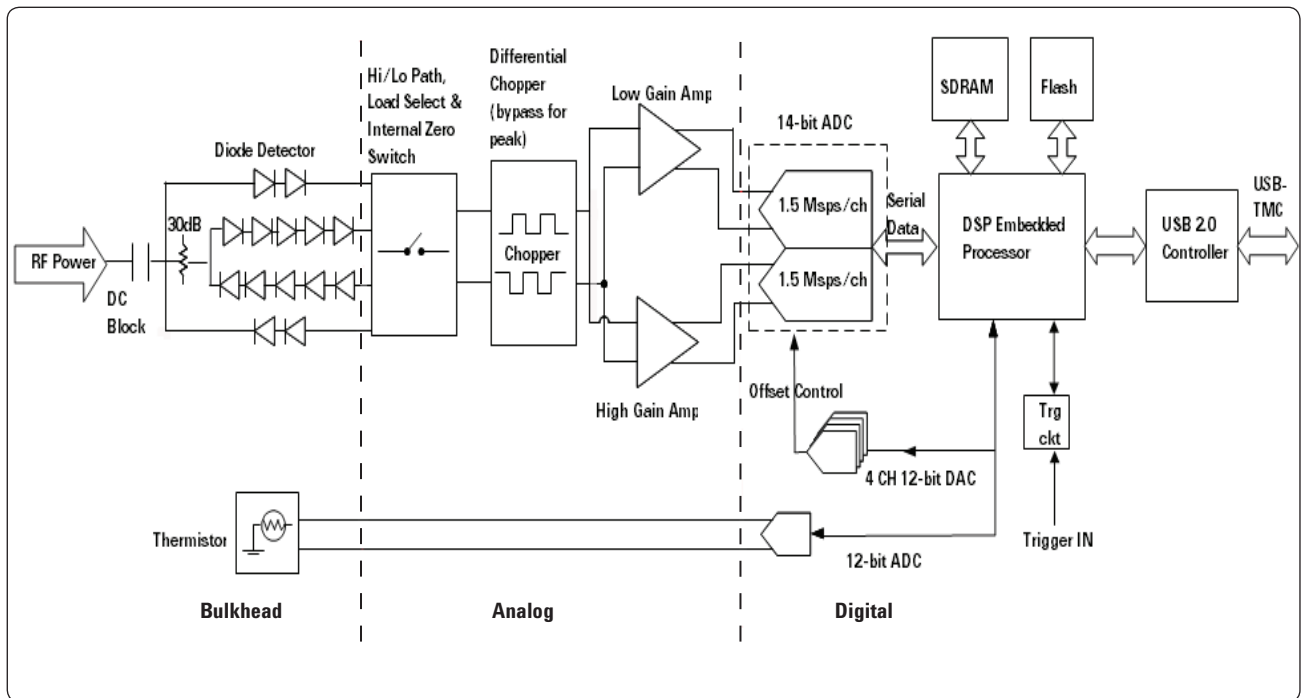

Figure 6 U2000 Series block diagram, showing the internal processing of power data. The diode stacks are shown abbreviated graphically, the actual low power path has 2-diode balanced stacks and the high power path has 5-diode stacks.

In brief, the input RF/microwave power drives two measurement channels, one for the lower level signals and the other through a resistive 30 dB attenuator for the high level channel. At the transition power point, approximately -10 dBm, the internal circuitry determines which channel will provide the output data. Amplification and signal conditioning assure that drift and gain stability are not compromised before hitting the high performance 14-bit analog-to-digital converter modules. From there, the digitized power data enters the processor which operates as an on-board computer for the self-contained sensor.

The processor controls all the housekeeping details, monitors its sensor temperature, and provides data corrections for the frequency calibration factor. It also determines which high-low channel to read, prepares the raw digitized data for the USB communications bus, and

receives command information from the PC or instrument controller. The processor reacts to the external trigger signal and maintains corrections for the analog signal and analog-to-digital converter offset signals.

The most obvious controller for the "Smart Sensor" is the ever-present PC or laptop. All modern computers have provisions for USB data connections, and setting them up is as simple as hooking up any peripherals to the PC.

It is calibration factor versus frequency, and also versus temperature. Temperature within the power sensing diode bulkhead is monitored by the thermistor shown in the block diagram in Figure 6 and this temperature data is used in the correction algorithm. The block diagram in Figure 6 shows two on-board memory modules that supplement the basic microprocessor.

The 64 MB synchronous dynamic random-access-memory (SDRAM) is a general purpose RAM, used for most of the variables data such as offset tables, calibration tables and corrected power readings. The 4 MB Flash Memory contains the instrumentation firmware and correction algorithm that corrects for frequency response of the sensor, using a 3-dimensional data matrix.

One of the key features of the U2000 Series is that it does not require daily calibration. The U2000 Series comes with pre-written calibration data in the memory of the sensor. The compact design of the U2000 Series which combines all the meter and sensor electronics in a small casing eliminates the need to use an external reference source for sensor calibration.



Figure 7 Instant interfacing of the U2000 Series with the Power Panel using a USB cable can be up to 5 meters long. Signal cable extension techniques for as long as 90 meters, using a LAN, will be covered later in this note.

Users can now rely on the yearly factory or the service center calibration to remove the gain or loss of the measurement path which is now a fixed loss. The internal zeroing and calibration-free designs remove the need for connection and disconnection of the sensor from the calibration source. This way, test times are reduced as well as the degree of measurement uncertainty and the wear and tear on the connectors. The calibration data can be modified later during its annual visit to the customer's Metrology Lab, or back at the service center.

Another advantage of the U2000 Series is that the devices can be coupled with other instrumentations, especially those with internal microprocessor controls. This allows standalone instruments to extend their performance for accurate absolute power measurements. Figure 8 shows the U2000 Series being controlled by a modern spectrum analyzer, where its display is configured to read the power parameter on a simulated analog power meter.



Figure 8 Intelligent instruments like the Agilent N9020A MXA Spectrum Analyzer can add accurate power measurements to their other capabilities by attaching a U2000 Series.

N1918A Power Analysis Manager Product Concept and Capabilities

Once the data is digitized, power measurement data which is derived from the U2000 Series power sensors or P-Series power meter can be processed in different ways. The N1918A Power Analysis Manager provides powerful analysis tools for a variety of purposes, which are summarized here.

The N1918A is available in two configurations:

- Power Panel, Basic: Bundled with the purchase of the U2000 Series USB Power Sensor.
- Power Analyzer, Option 100, Advanced: Licensed version, with extended performance capabilities, such as pulse analysis and power statistics analysis.

The N1918A is compatible with a variety of sources:

- U2000A/1A/2A/4A USB sensors
- N1911/1912A P-Series power meters
- N8262A P-Series modular power meter LXI-C compliance

The N1918A software operates on Windows® platforms in the following configurations:

- PC or laptop
- Smart instruments with internal processors such as N9020A MXA Spectrum Analyzer
- Third-party devices based on Windows platforms

The key performance characteristics of the Power Analysis Manager are as follows:

Basic, Power Panel:

- Processes and displays multiple channels of power measurement
- Provides larger, enhanced visual displays
- Performs ratio or difference computations between data from two channels (see Figure 9)
- Transfers instrument settings from one sensor data set to another
- Compatible with Microsoft® Excel®
- Stores up to 10,000 measurement points

Option 100, Power Analyzer:

- Enhanced visualization with bigger and flexible display formats
- Provides complete pulse power characterization (15 pulse parameters)
- Supports overlay measurements (limit, min, max, delta) and channel math computations
- Computes powerful statistical power routines on communications measurements, such as PDF, CDF and CCDF
- Stores up to seven days worth of data from preprogrammed measurement time schedules
- Limit and alert function for remote monitoring

Users should consult the N1918A Data Sheet for further details on these two software packages. The following figures provide sample screenshots of the application.



Figure 9 A typical soft front panel display for the basic N1918A Power Analysis Manager with an analog dial plus a digital readout.

In Figure 11, the Power Analyzer provides four display formats; Digital Softpanel, Strip Chart, Analog Gauge and Trace Graph. The Power Analyzer supports and manages more than ten sensors and displays up to four data results in a single tab. Furthermore, users can also create multiple tabs to support multiple measurements. Users can save and restore their instrument settings. The Power Analyzer can be programmed in order to record specific measurements using a specific setup at a specific or repetitive time. The archived data is available for later analysis.

The N1918A Power Analysis Manager accepts power data from both the power meters and the U2000 Series sensors at the same time. As shown in Figure 20 later on, it can then compute complex statistical data like CCDF. At the same time it can monitor other power data using a digital display and overlay comparison routines.

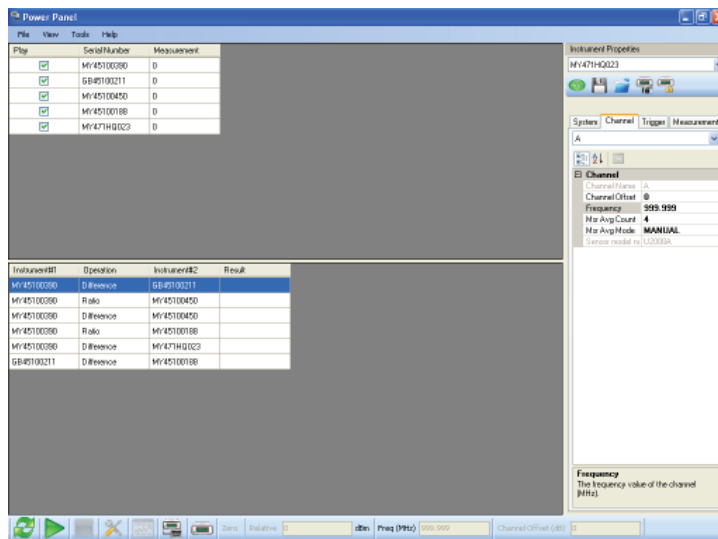

Figure 10 The Power Panel shows a multi-list measurement view of power data in the top table, and ratio and difference computation results between two or more channels in the bottom table.



Figure 11 The Power Analyzer shows a powerful customizable display configuration of various data inputs. In this case, four completely different types of measurement processes are displayed in a single tab.

Measurement Applications of the U2000 Series USB Power Sensor

With the performance capabilities and data flexibility of the new U2000 Series and the Power Analysis Manager, measurement engineers have the ready-to-use solutions at hand for the power measurement requirements of their applications. The following suggested applications will serve to stimulate their creativeness.

Remote Power Measurements

One of the serious limiting factors of the traditional power meter and sensor instrumentation is that the connection cable between them carried ultra-low-level analog signals. Thus, the cable placed definite limits on the distance between the sensor and the meter. The U2000 Series converts the power data to digital format, hence power measurement can be made over very long distances.

Figure 12 shows a remote antenna which requires transmitter power monitoring on a regular basis. By permanently installing the U2000 Series on a power tap-off, and arranging the data connection through LAN formats, the actual power monitor can be in the antenna system control room hundreds of feet away. The USB data transfer capabilities limit the cable length to about 5 meters, so in this case, an Agilent E5813A USB-to-LAN hub converter is used. The typical LAN operating distance can be up to 90 meters or more, which is about the length of a football field, that should easily handle the remote antenna sites.

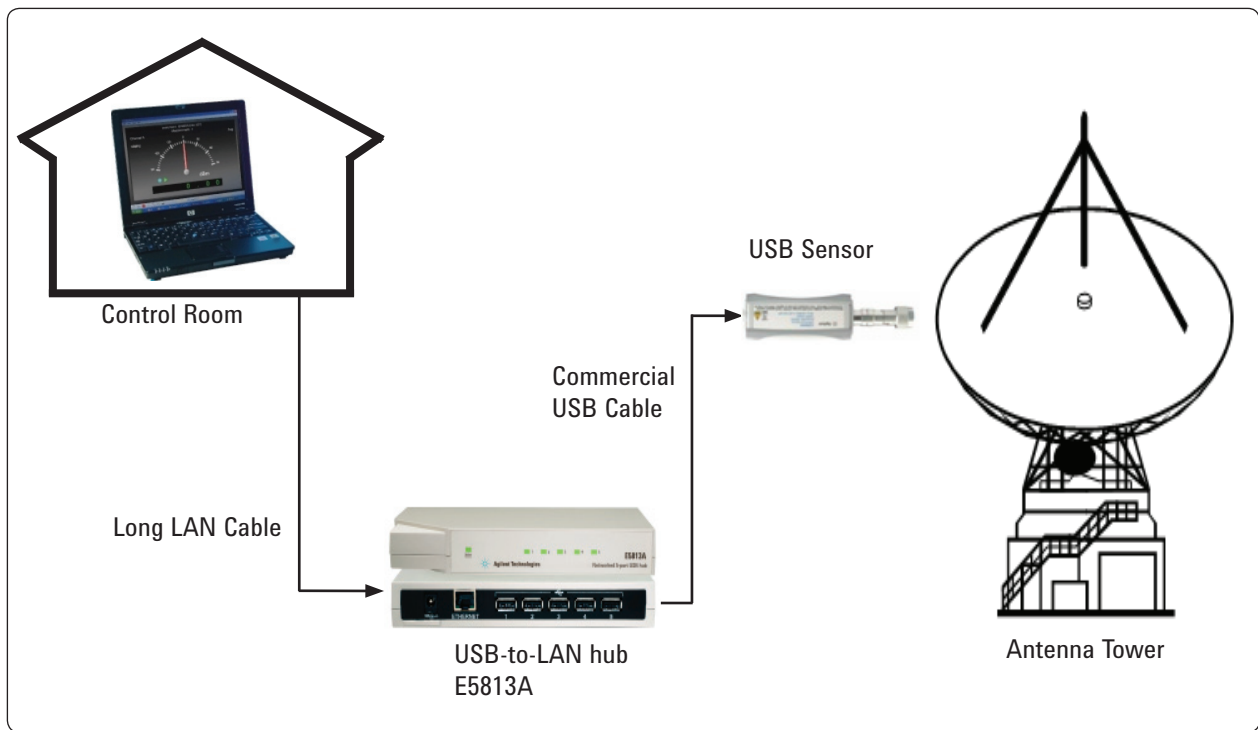

Figure 12 A far remote power sensor converts the monitored system power to digital data, which is transferred to the control room computers through a commercial USB cable and LAN data extension.

Portable Power Measurement – Mobile Power Acquisition and Data Logging

While previous power meters have been available in battery-operated configurations, they only permitted simple local measurement functions. The U2000 Series allows mobile operation using a laptop operating with a minimum power, fed through the USB data cable from the laptop's battery. Thus, measurements can be easily made at remote sites, such as wireless base stations. With its light weight and small size, the U2000 Series and accompanying laptop can be carried with ease by a service technician to the top of an antenna tower for routine power measurements.

By leveraging the data archiving capability of the Power Analysis Manager, this mobile measuring system is able to log base station power characteristics as the maintenance technician travels from one base station to another. The station data is then preserved for later analysis back at the service center. Thus, this PC and U2000 Series instrumentation can be considered as mobile power logger, allowing the technician to store measurement data to easily configured data files that eventually eliminates manual test data forms.

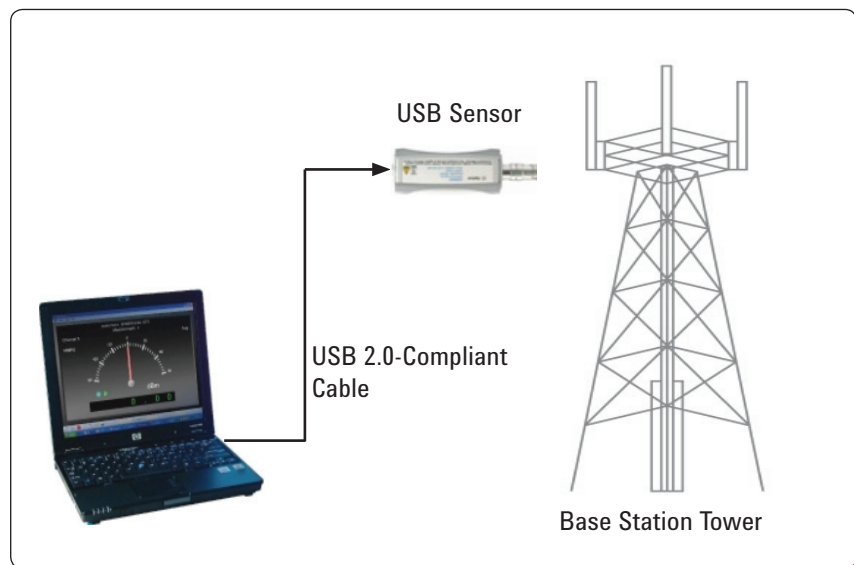

Figure 13 The USB offers plug-and-play capability for remote power measurement on an ordinary laptop with its rechargeable battery and providing power for the U2000 Series from its own USB data port.

Multiple-Channel Power Measurements

Many power measurement applications do not allow engineers to sense multiple power points simultaneously and rather require them to move single sensors from point to point. This is where the USB signal multiplexer can be used because it can sequence data from as many as ten channels of USB data from ten U2000 Series sensors.

The U2000 Series application can be applied on a high-volume production line where large quantities of wireless cell phones are measured for output power on test stations that are located next to each other.



Figure 14 By multiplexing more than ten channels of USB power data with an electronic USB multiplexer, simultaneous data can be obtained from every sensor point and displayed on the versatile Power Analysis Manager.

Computed Parameters from Multiple Sensors' Measurements

Scalar network analyzers play a prominent role in microwave component characterization, such as reflection coefficient and gain. However, there may be times when actual power sensing is much more preferred. For instance, in power amplifier measurements, when the specified output power is required for the production specification. In Figure 15, the U2000 Series is used to sample three power parameters; input power, reflected power using a directional coupler, and amplified output power. The power data provides for computed reflection coefficient (return loss), gain, and a definitive, accurate, and traceable output power. The USB sensor combination, shown with associated computations of reflection coefficient or gain represents a lower cost solution than a traditional scalar network analyzer, especially if the same test component unit requires a real output power specification test.

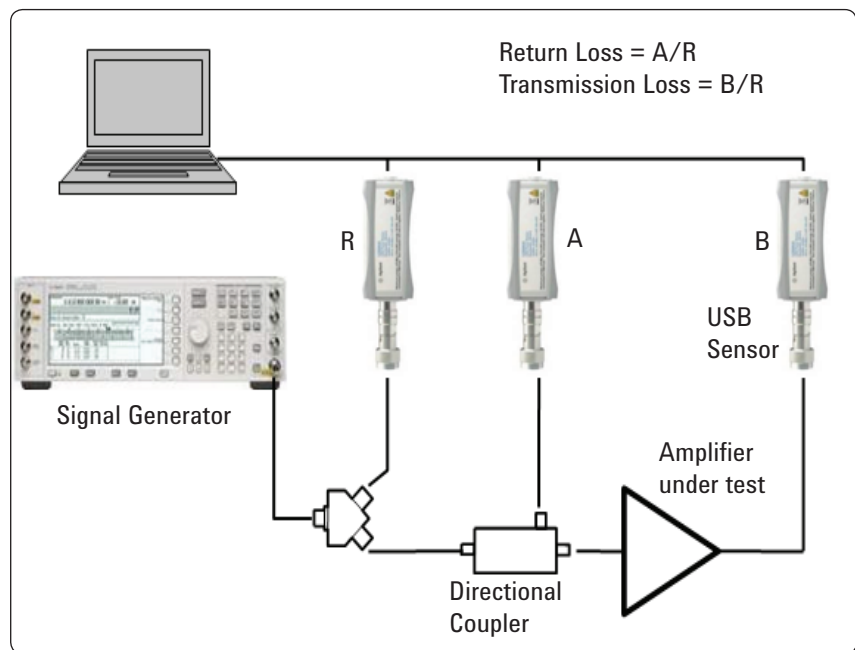

Figure 15 In measurement applications where absolute power data is required, power sensors can measure the absolute output power for assuring compliance and also furnish the power data which permits computing ratios such as return loss and gain, at specified input power conditions.

Obtaining Absolute Power Measurements on Associated Measuring Instruments

Many modern test instruments have powerful signal processing and displays of a variety of important parameters. Spectrum analyzers provide many different signal characteristics versus frequency, including nominal power levels of unknown signals. Network analyzers, with their multi-band signal sources are great for measuring S-parameters of all sorts of passive and active components. Digital signal analyzers also characterize the digital formats of common communications signals.

However, none of these instruments, in spite of their on-board computers and analysis, can obtain an absolute power measurement of the signal under test. The U2000 Series can be included in those measurement setups and feed absolute power measurement data directly to the main measurement instrument on-board processor.

Alternatively, the U2000 Series can be used to assure the output power specifications of the transceiver, without needing an extra power meter. This can be applied to a signal generator that is used to stimulate a sub-system under test, for example, a transceiver within the microwave frequency range.



Figure 16 The U2000 Series is connected to the USB port of a Vector Network Analyzer (VNA) and the measured power is displayed on the VNA screen.

Measurements that Requires Real-Time Synchronization (Trigger)

Some data bus cabling, such as USB or GPIB, allows a certain degree of measurement synchronization (in the millisecond range). However, in many measurement environments, real-time triggering is a necessity. These will call for trigger synchronization in the microsecond region. The following sections provide several suggested applications:

- If more than one U2000 Series is used in a system monitoring application, all the sensors are to monitor the power signal with complex modulation. There may be a need to synchronize the data sampling to coincide with the communications clock. In this application, a common video trigger pulse will be used to connect to all the real-time trigger inputs of the multiple sensors. Typical communications formats are the GSM (pulsed) signals.
- The triggering port can also be used to synchronize the measurements with an external instrument or event, for instance, the calibration of the output power of a synthesizer that is sweeping in frequency. The triggering port can be used to accept a trigger signal from the synthesizer to initiate the measurement with every frequency step.

Measurement Applications of the N1918A Power Analysis Manager

The N1918A Power Analysis Manager is a suite of application tools that comprises a basic version which comes with the purchase of the U2000 Series, and an advanced version, Option 100, which is an optional, licensed software. The technical data sheet for the N1918A describes the differences in the performance and capabilities for the two versions in detail. The following applications are intended to provide the measurement engineer with power requirement information in order to check if the statistical routines, data archiving provisions, and manipulation information are sufficient. Figure 17 provides an overview of the different capabilities.

Data Gathering Function

The N1918A Power Analysis Manager is a multi-faceted software application, running on Windows operating systems, which multiplies the measurement and diagnostic power of a user's power data collection. In its simplest configuration, it gathers power measurement data from three typical sources, as shown in Figure 17: the N1911/12A P-Series Power Meter, the N8262A P-Series Modular Power Meter and the U2000 Series USB Power Sensor.

All the data that is provided is formatted on the basis of the Standard Commands for Programmable Instrumentation (SCPI). SCPI defines a uniform and consistent language for the control of test and measurement equipment, and the transfer of data. [3] The transfer of data can be done through any of these three data and control buses; USB, GPIB or LAN connectivity, which are generally available on most modern power meters.

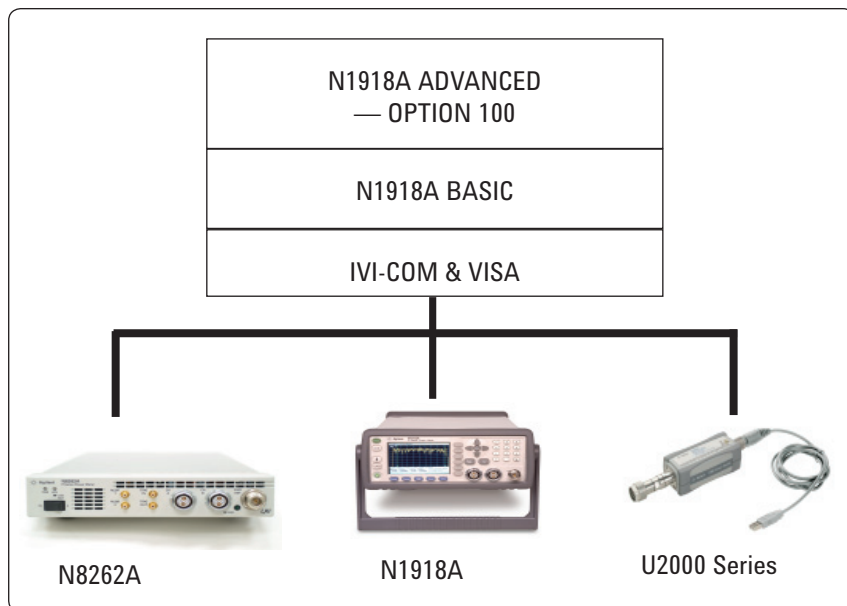

Figure 17 The N1918A Power Analysis Manager interfaces with power measurement data from various sources, two power meters as shown, plus the U2000 Series.

Table 1 Overview of the software capabilities for the two versions of the N1918A Power Analysis Manager.

	Power Panel (basic)	Power Analyzer (advanced)
Compatible Hardware		
Instruments supported	U2000 Series USB Power Sensors, N1911A P-Series Single-Channel Power Meter, N1912A P-Series Dual-Channel Power Meter, N8262A P-Series Modular Power Meter	
Measurement Displays -- Easy to learn and flexible display format		
Digital Softpanel Display	✓	✓ (Enhanced with MIN/MAX measurement, limits and alerts notification)
Gauge Display	✓	✓ (Enhanced with MIN/MAX measurement, limits and alerts notification, gauge scale)
Strip Chart Display	✓	✓ (Enhanced with display options)
Trace Graph Display	✓*	✓
Multiple Tabs	✗	✓
Multiple Channel List	✓	✗
Graph Functions -- Powerful features to meet your demanding needs		
Single Marker	✓ (one marker only)	✓ (Up to 10 markers per graph)
Dual Marker	✗	✓ (Up to five sets per graph)
Graph Autoscaling	✓	✓
Graph Zooming	✗	✓
Measurement Math	✓ (Difference, Ratio)	✗
Pulse Characterization -- Alternative to a peak power analyzer, comprehensive pulse parameters characterization		
15-Point Pulse Characterization	✗	✓
Gate Measurement Analysis	✓*	✓ (One per Trace Graph)
Overlay Trace Graph	✗	✓
Waveform Math	✗	✓ (Delta, Plus, Ratio)
Trigger Level Indicator	✗	✓ (Only applicable in Trace Graph)
Statistical Analysis Function -- Measures and computes CCDF, CDF, PDF		
CCDF/CDF/PDF	✗	✓
Save/Load File Functions -- Convenient data logging and storing		
Save Measurement Data	✓ (Applicable in Power Time Graph)	✓ (Only applicable in Strip Chart, Trace Graph, CCDF/CDF/PDF Graph)
Load Measurement Data	✓ (Applicable in Power Time Graph)	✓ (Only applicable in Strip Chart, Trace Graph, CCDF/CDF/PDF Graph)
Data Recording	✗	✓ (Only applicable in Trace Graph**, Digital Softpanel, Strip Chart, Gauge with up to seven days of recording time)
Save Instrument Screen Image	✓	✓
Instrument Settings Options -- Loaded with time-saving feature		
Save and Restore Instrument Settings	✓	✓
Measurement Limit and Alert Function -- Optimized for remote operation		
Limit and Alert Notification	✗	✓
Alert Summary	✗	✓
Printing Options -- Simple and easy-to-use print option		
Print Application Screen	✗	✓

Providing Comprehensive Pulsed Signal Characterization with all Pulse Parameters

The Agilent 8990A Peak Power Analyzer pioneered the comprehensive signal characterization of pulsed microwave signals approximately in 1990. It has become obsolete some years ago. When you combine the N1918A Power Analysis Manager with a P-Series power meter, including its peak and average sensors, the complete 15 pulse parameters' real-time and computed data are immediately shown on the screen. In addition, it can perform these computations for more than one power channel at a time, which is an important capability.

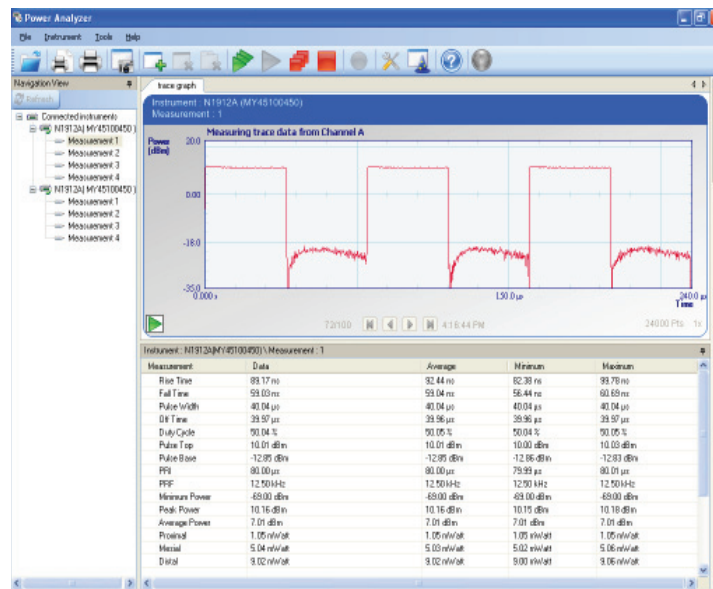

Figure 18 The Power Analyzer screen displays the 15 measured and computed parameters that characterize the RF/microwave pulse power completely when pulsed data is captured on the P-Series power meters.

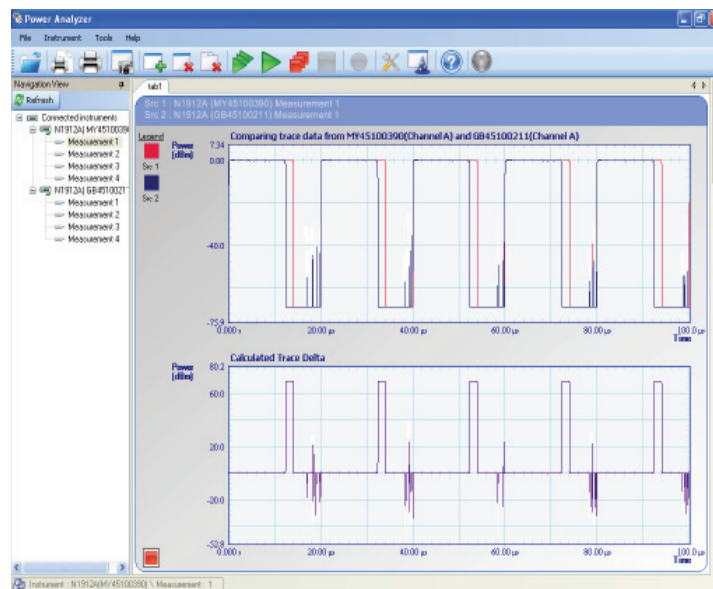

Figure 19 The overlay trace function provides the computed delta trace, which shows the differences between pulsed data of Measurement Devices 1 and 2.

Measuring and Computing PDF, CDF, and CCDF Statistical Parameters

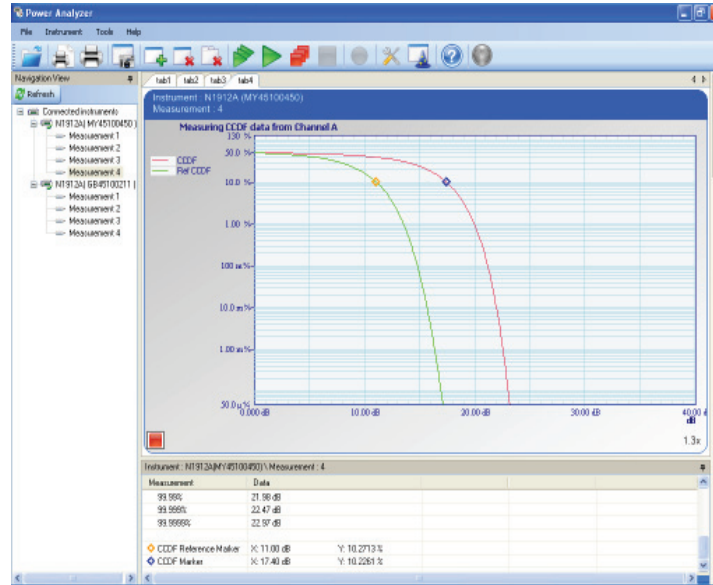

Figure 20 The computed CCDF function is an important system performance parameter for wireless system engineers. The statistical measurements can be easily provided by the Power Analyzer. It can display statistical parameters in both tabular and graphical display formats.

Control Tower Monitoring of Types of Power Functions

Figure 21 shows four different monitoring and computed power functions on one screen at the same time. It may not occur regularly that so many entirely different power data results need to be viewed simultaneously, but the capability does exist.

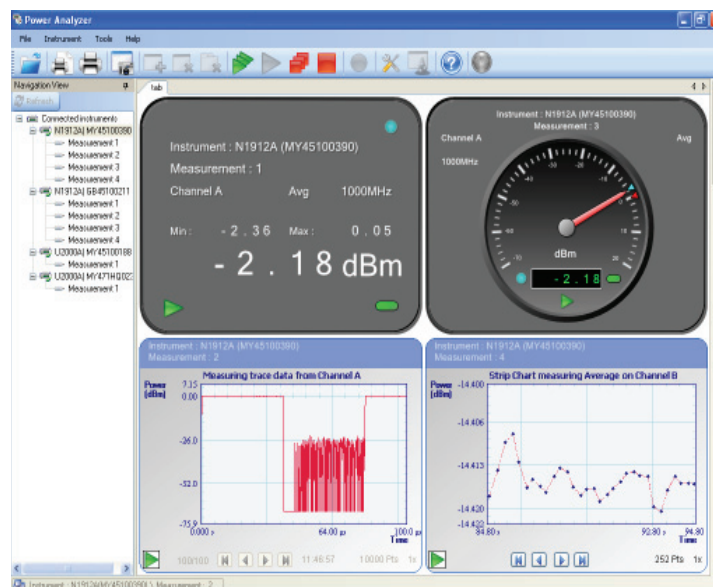

Figure 21 The Power Analyzer is able to control measurements and displays of four completely different power data processes and results in one single tab.

Record and Load Function

The record and load function allows you to store data of up to seven days based on preprogrammed measurement schedules. Thus, data can be archived and loaded for later viewing or use. The data is stored in a comma-separated value file (CSV), which is compatible with Microsoft Excel.

This function can be used to troubleshoot equipment which exhibits random and unwanted changes in the power output. It can also be used for long-term monitoring of test processes that run unattended for several days in a row. While such programming can always be done using traditional test software, this built-in test capability of the N1918A Power Analysis Manager just makes it all more convenient.

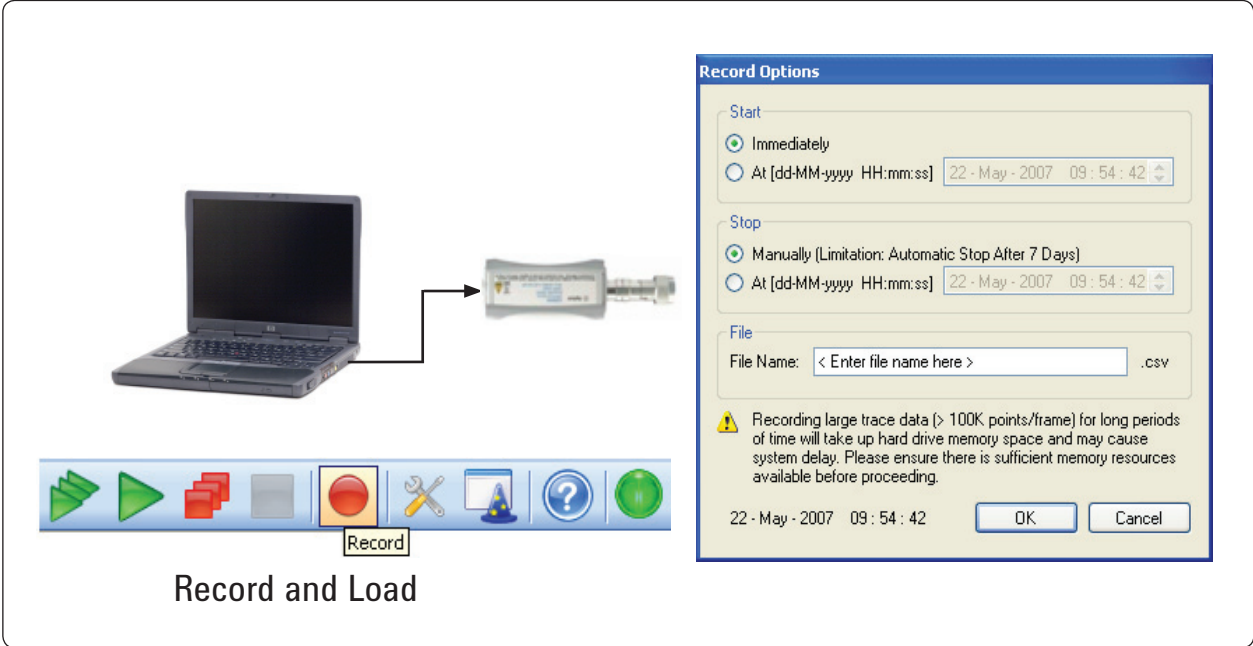

Figure 22 The record options and tools of the N1918A Power Analysis Manager.

Measurement Tips, Calibration, Traceability, and Measurement Uncertainties

5.1 Measurement Tips

There are four important steps that are necessary to achieve better power measurement results:

- Understanding the modulation formats of the signal under test,
- Understanding the power sensor technology and operating principles,
- Understanding the principles of power measurement traceability, and
- Selecting the right sensor and PC, power meter or display for the signals under test.

These principles are discussed in detail in Application Note 64-4D, "4 Steps for Making Better Power Measurements." [2] To achieve optimum results in measuring power with the new USB power sensors, it is recommended for users to read the referenced note. Of course, since the USB sensors feature CW and average power measurements, we will briefly review the above four steps with regards to the specific performance of their diode-stack sensor configuration.

Getting to know the performance capabilities of the diode sensors is important in order to understand how they process test signal formats. For example, do signal crest factors or peak power spikes cause the diode sensor to deviate from the dynamic range square-law detection? High crest factors can occur in modern wireless signal formats. Do the averaging processes inside the digitizing sensor depend on a synchronization between the digital-sampling periods and the digital data clocks of the wireless signal?

The U2000 Series sensors are based on the LBS technology, pioneered by Hewlett-Packard in 1975. Throughout the last three decades, dramatically improved products have been introduced. For example, the U2000 Series is partially based on the diode configurations used in the popular Agilent E9300-Series wide-dynamic range average-power sensors. An extensive technical description of the E9300-Series diode technology is given in AN 1449-2. [Ref: 1.2, page 24 — 29]

To achieve the expanded dynamic ranges (-60 to +20 dBm), diode stacks are incorporated in place of single diodes, to extend the square-law conversion range to higher power levels (+20 dBm in this case) at the expense of a little sensitivity (see Figure 23). For example, a series connection of (m) diodes results in a low-level sensitivity degradation of 10 log (m) dB. But, (m) diodes provide an extension upwards in power limits of the square-law detection region maximum power of 20 log (m) dB. This yields a net improvement in square-law dynamic range of 10 log (m) dB, compared to a single diode configuration.

The U2000 Series sensors are implemented as a modified barrier integrated diode (MBID) on one chip [4], with a 1-diode balanced pair for the low power path (-60 dBm to -10 dBm), a 30 dB-resistive divider attenuator and a 2-diode stack pair for the high power path (-10 dBm to +20 dBm), as shown in Figure 6.

The U2000 Series sensors' architecture is based on a data-compensation algorithm that is calibrated and stored in an individual SDRAM resident in each sensor. The data algorithm stores the information of three parameters, input power level vs. frequency vs. temperature for the range of 9 kHz to 24 GHz and -60 dBm to +20 dBm and 0°C to 55°C, depending on the model number.

Naturally, since the U2000 Series is self-contained and requires a substantial internal circuitry to achieve digital conversion and measurement communication on the USB bus, the SDRAM and Flashdrive memory technologies exhibit a non-volatile-type data storage.

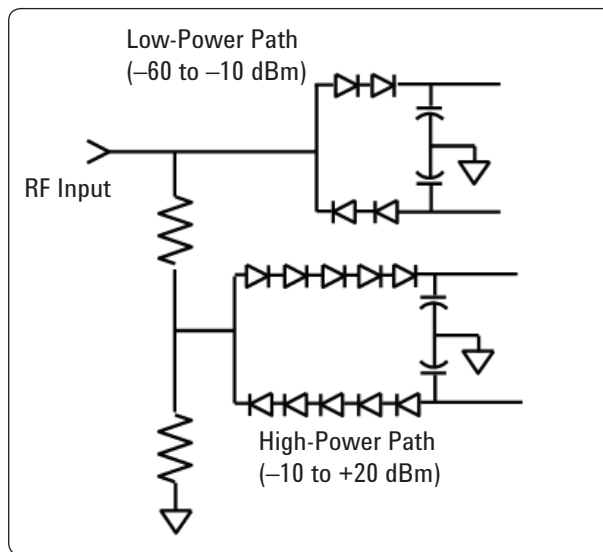

Figure 23 The RF/microwave diode stacks are super-integrated onto a single MBID which combines channel switching and the on-board power zeroing function.

Signal Formats

The wide-dynamic square-law range of the U2000 Series sensors makes them ideally suited to measure signal formats with complex modulation formats which cause high crest factors. The principle is that the peaks of the crest factor spikes do not exceed the square-law detection range. Crest factors of ten are easily handled by assuring that the measurement range of the sensor is dialed down in such a way that the peak power does not exceed +20 dBm.

For users measuring complex power formats with high crest factors, it is recommended that they refresh their background on signal formats on the use of dual path sensors by referring to [Ref: 2, pages 29 – 30] [Ref: 2, pages 3 – 6].

Applications that require power measurements of pulsed RF/microwave signals (such as radar signals) are covered in the U2000 Series too, provided that it is permitted to just measure the average power of the pulsed modulation waveform. In many if not most of the system tests, pulsed power transmitters have fixed duty cycle (peak power duration divided by pulsed repetition period), thus, an average power reading can be computed to peak power. Again, for proper averaging, it must be assured that the peak pulse power entering the U2000 Series does not exceed +20 dBm so as not to get out of square-law range. This may require an external microwave attenuator pad of 10 dB or 20 dB.

Calibration, Zero and Cal

The calibration factor versus frequency versus temperature characterization is done once at the factory during manufacturing to measure each individual diode stack assembly for temperature variations. The data that is run against a frequency response test forms the basis for the 3-dimensional correction table stored on-board within the U2000 Series in the SDRAM and Flashdrive. [Ref: 5]

The test of the stability of the correction table over several time periods has resulted in recommendations that re-calibration is only required once per year. The sensor works within a specified warranty period of one year. Furthermore, when the yearly calibration cycle is due, the calibration facility only needs to make a frequency response test at laboratory temperature (25°C). It has been determined that the temperature sensitivity profile stays constant over time as long as no overload damage

has been experienced. The crucial point of remote installations of the U2000 Series is the capability to perform automatic zeroing without having to disconnect the RF connector at the power sensing point, or shut down the system power. This function is described as an integrated function on-board the same microcircuit that holds the diode stacks, and the signal switching from high to low sensitivity channels. [Ref: 5]

The calibration process may be performed by returning the U2000 Series to the Agilent Service Facility or it can be done in the user's Cal Lab. Once the new correction data is obtained, instructions are available to permit the calibration facility to input new data tables into the individual sensor via the USB communications bus.

Traceability and Uncertainty

All the previous technology history and knowledge acquired in using Agilent's power measurement equipment is preserved in the U2000 Series. Agilent follows international standards and processes for assuring traceability to NMIs (National Measurement Institutes) such as NIST in the U.S. Agilent's Application Note 1449-3, which provides exhaustive documentation on the subject. [Ref: 3]. This includes not only the detailed analysis of uncertainty factors, but also extensive recommendations on how to improve measurement uncertainty and at the same time reduce the effects of mismatches, and so forth.

Since the U2000 Series might be placed into operation in a location that does not have ready access to a "Standard 50 MHz, 1 mW power source," the user will probably need to rely on the stability of the on-board correction data. However, in critical measurements, with legal or economic considerations, it is always possible to arrange to bring a traditional Agilent power meter to the measuring point, or return the U2000 Series to an available power meter and create the simple 50 MHz, 1 mW point reference.

References

- [1] Zurakowski, M, et al, Nov, 1986, *Diode Integrated Circuits for MM Applications*, Hewlett-Packard Journal.
- [2] Anderson, Alan B., June, 2005, *In Context – Internal Zero and Calibration for RF Power Sensors*, RF Design.
- [3] Anderson, Alan B., October, 2000, *Measuring Power Levels in Modern Communication Systems*, MW/RF Magazine.

Related Literatures

- [1] *Agilent Fundamentals of RF and Microwave Power Measurements (Part 1), Introduction to Power, History, Definitions, International Standards and Traceability*, Literature Number 5988-9213EN
- [2] *Agilent Fundamentals of RF and Microwave Power Measurements (Part 2), Power Sensors and Instrumentation*, Literature Number 5988-9214EN
- [3] *Agilent Fundamentals of RF and Microwave Power Measurements (Part 3), Power Measurement Uncertainty per International Guides*, Literature Number 5988-9215EN
- [4] *Agilent Fundamentals of RF and Microwave Power Measurements (Part 4), An Overview of Agilent Instrumentation for RF/microwave Power Measurement*, Literature Number 5988-9216EN
- [5] *Agilent 4 Steps for Making Better Power Measurements*, Literature Number 5965-8167EN

Related Web Resources

For SCPI standards, refer to the following URL:

www.scpiconsortium.org/scpiinfo2.htm.



Agilent Email Updates

www.agilent.com/find/emailupdates

Get the latest information on the products and applications you select.



Agilent Direct

www.agilent.com/find/agilentdirect

Quickly choose and use your test equipment solutions with confidence.



www.agilent.com/find/open

Agilent Open simplifies the process of connecting and programming test systems to help engineers design, validate and manufacture electronic products. Agilent offers open connectivity for a broad range of system-ready instruments, open industry software, PC-standard I/O and global support, which are combined to more easily integrate test system development.

Windows and Excel are the US registered trademarks of Microsoft Corporation in the United States and/or other countries.

Remove all doubt

Our repair and calibration services will get your equipment back to you, performing like new, when promised. You will get full value out of your Agilent equipment throughout its lifetime. Your equipment will be serviced by Agilent-trained technicians using the latest factory calibration procedures, automated repair diagnostics and genuine parts. You will always have the utmost confidence in your measurements.

Agilent offers a wide range of additional expert test and measurement services for your equipment, including initial start-up assistance on site education and training, as well as design, system integration, and project management.

For more information on repair and calibration services, go to

www.agilent.com/find/removealldoubt

www.agilent.com

For more information on Agilent Technologies' products, applications or services, please contact your local Agilent office. The complete list is available at:

www.agilent.com/find/contactus

Phone or Fax

United States:
(tel) 800 829 4444
(fax) 800 829 4433

Canada:
(tel) 877 894 4414
(fax) 800 746 4866

China:
(tel) 800 810 0189
(fax) 800 820 2816

Europe:
(tel) 31 20 547 2111

Japan:
(tel) (81) 426 56 7832
(fax) (81) 426 56 7840

Korea:
(tel) (080) 769 0800
(fax) (080) 769 0900

Latin America:
(tel) (305) 269 7500

Taiwan:
(tel) 0800 047 866
(fax) 0800 286 331

Other Asia Pacific Countries:
(tel) (65) 6375 8100
(fax) (65) 6755 0042
Email: tm_ap@agilent.com
Revised: 1%/06

Product specifications and descriptions in this document subject to change without notice.

© Agilent Technologies, Inc. 2007
Printed in USA, August 29, 2007
5989-7268EN



Agilent Technologies